

# LGSD/NGSD: High Speed Optical CMOS Imagers for E-ELT Adaptive Optics

Mark Downing<sup>\*a</sup>, Johann Kolb<sup>a</sup>, Philippe Balard<sup>c</sup>, Bart Dierickx<sup>c</sup>, Arnaud Defernez<sup>c</sup>, Philippe Feautrier<sup>d</sup>, Gert Finger<sup>a</sup>, Martin Fryer<sup>b</sup>, Jean-Luc Gach<sup>e</sup>, Christian Guillaume<sup>f</sup>, Norbert Hubin<sup>a</sup>, Paul Jerram<sup>b</sup>, Paul Jorden<sup>b</sup>, Manfred Meyer<sup>a</sup>, Andrew Payne<sup>b</sup>, Andrew Pike<sup>b</sup>, Javier Reyes<sup>a</sup>, Robert Simpson<sup>b</sup>, Eric Stadler<sup>d</sup>, Nick Swift<sup>b</sup>.

<sup>a</sup>ESO, Karl-Schwarzschild-Strasse 2, 85748 Garching, Germany;

<sup>b</sup>e2v technologies, 106 Waterhouse Lane, Chelmsford, Essex, CM1 2QU, England;

<sup>c</sup>Caeleste, Generaal Capiaumontstraat 11, 2600 Antwerp, Belgium;

<sup>d</sup>Institut de Planétologie et d'Astrophysique, BP 53 38041 Grenoble France;

<sup>e</sup>LAM, Laboratoire d'Astrophysique de Marseille, 2 place Le Verrier, 13248 Marseille France;

<sup>f</sup>OHP, Observatoire de Haute Provence, 04870 St.Michel l'Observatoire, France.

## ABSTRACT

The success of the next generation of instruments for ELT class telescopes will depend upon improving the image quality by exploiting sophisticated Adaptive Optics (AO) systems. One of the critical components of the AO systems for the E-ELT has been identified as the optical Laser/Natural Guide Star WFS detector. The combination of large format, 1760x1680 pixels to finely sample the wavefront and the spot elongation of laser guide stars, fast frame rate of 700 frames per second (fps), low read noise ( $< 3e^-$ ), and high QE ( $> 90\%$ ) makes the development of this device extremely challenging. Design studies concluded that a highly integrated Backside Illuminated CMOS Imager built on High Resistivity silicon as the most likely technology to succeed. Two generations of the CMOS Imager are being developed: a) the already designed and manufactured NGSD (Natural Guide Star Detector), a quarter-sized pioneering device of 880x840 pixels capable of meeting first light needs of the E-ELT; b) the LGSD (Laser Guide Star Detector), the larger full size device.

As well as presenting the detailed design including the approach of using massive parallelism (70,400 ADCs) to achieve the low read noise at high pixel rates of  $\sim 3$  Gpixel/s and the 88 channel LVDS 220Mbps serial interface to get the data off-chip. To enable read noise closer to the goal of  $1e^-$  to be achieved, a split wafer run has allowed the NGSD to be manufactured in the more speculative, but much lower read noise, Ultra Low Threshold Transistors in the unit cell. The NGSD has come out of production, it has been thinned to  $12\mu\text{m}$ , backside processed and packaged in a custom 370pin Ceramic PGA (Pin Grid Array). First results of tests performed both at e2v and ESO are presented.

**Keywords:** Adaptive Optics Detector, AO Wavefront Detector, Wavefront Sensor, CMOS Imager, CMOS Image Sensor, LGSD, E-ELT WFS.

## 1. INTRODUCTION

Spot elongation<sup>[1]</sup> of Laser Guide Star (LGS) is considered one of the major challenges of Adaptive Optics (AO) WaveFront Sensor (WFS) systems of ELTs. The spot elongation is due to the finite thickness of the sodium layer and the offset between the laser projection point and the sub-apertures of a Shack-Hartmann (SH) WFS. The elongation or spreading of the Laser Guide Star (LGS) image results in a decrease in the signal to noise ratio (SNR) resulting in an increase of the centroid error, and subsequently increased error of the wavefront phase reconstruction.

The current LGS WFS system for the E-ELT (an adaptive Telescope) baselines the following: 1) 4 Continuous Wave (CW) Sodium LGSs projected from the sides of the telescope; 2) enough laser power to provide 1000 photons per sub-aperture per frame, 3) high spatial sampling up to  $84 \times 84$  sub-apertures (goal of  $126 \times 126$  for later upgrade) and  $20 \times 20$  pixels per sub-aperture to adequately sample the spot elongation, and 4) high temporal sampling of 700 Hz.

From the top level science requirements, the following requirements for a large LGS/Natural Guide Star (NGS) AO WFS detector<sup>[2]</sup> (code named LGSD) have been justified:

- 1) Minimum format size of 1680x1680 pixels,
- 2) Big pixels of 20-28 $\mu$ m, to ease the optical system design (mechanical alignment and stability), but small enough to avoid excessive dark current/counts, charge transfer inefficiency (image lag), or manufacturability problems,
- 3) Versatility of 100% fill factor for maximum flexibility; to make it possible to decide later to change laser projection site and/or mix of sub-apertures/pixels,
- 4) Low dark current and read noise such that total noise is  $< 3e$ - rms,
- 5) High Quantum Efficiency (QE) over wavelength of 450-950nm (for NGS applications) and especially at 589 nm (LGS wavelength),
- 6) Equivalent exposure time of frame rates from 100fps to 700fps with goal of 1000fps with slightly (gracefully) degraded performance,
- 7) Low read out latency (time between end of exposure and image available at output pin  $< 7$  % of exposure time) so that corrections can be computed and applied as quick as possible after the exposure ends,
- 8) Detection signal limit of 4000e-/pixel; laser power will be limited so the system will be photon starved (expect only 1000 photons per sub-aperture per frame),
- 9) Good spatial characteristics, Point Spread Function (PSF)  $< 0.8$  pixel FWHM (Full Width at Half Maximum), to accurately determine where the photons arrived,
- 10) As cosmetically defect-free as possible;  $< 0.1\%$  defective pixels,
- 11) Ease of use/compact size:
  - a. Low pin count; goal  $< 200$  pins,
  - b. Integrated read-out electronics with all video processing (including Correlated Double Sampling (CDS), noise bandwidth limiting, and programmable gain) and digitizing of signal (ADCs) on-chip,
  - c. Simple digital serial data interface with minimal glue logic to a FPGA,
  - d. Integral Peltier cooled package for compact size, maintenance free, and minimal support equipment. As a Peltier cooler is not able to remove a large amount of heat at great efficiency, an upper limit on the power consumption of  $< 5W$  is imposed on the detector.

To progressively retire risk, a multi-phased development plan was adopted for the development of LGSD in order to have detectors available on time for first light AO systems of the E-ELT in 2024. The phases being: (1) The Design Study which concluded that for the pixel size, format size, and frame rate, the most likely technology to succeed is a monolithic Backside Illuminated (BSI) CMOS Imager, (2) Technology Validation which retired pixel risks, (3) the current phase of designing, building, and testing the Natural Guide Star Detector (NGSD), a pioneering,  $\frac{1}{4}$  sized, scaled down demonstrator, to retire architectural and process risks, (4) The LGSD, the full scale development which should mostly be an engineering exercise, and (5) The Production Run where 30-50 devices will be manufactured.

This paper presents the detailed design of the NGSD/LGSD including the approach of using massive parallelism of up to 40 rows of pixels read in parallel (in total 70,400 ADCs) to achieve the low read noise at high pixel rates of  $\sim 3$  Gpixel/s and the 88 channel (in case of LGSD) LVDS 220Mbps serial interface to get the data off-chip; and the impressive first test results.

## 2. NGSD/LGSD DESIGN

In 2012, following on from the successful design and technology validation studies, ESO funded e2v<sup>1</sup>, with Caeleste<sup>2</sup> as the design sub-contractor, to develop a scalable quarter sized (880x840pixels) demonstration detector called NGSD to meet all requirements of the final full size device, the LGSD, except for the pixel format size. The chosen technology

---

<sup>1</sup> e2v, <http://www.e2v.com/>

<sup>2</sup> Caeleste, <http://www.caeleste.be/>

was monolithic Backside Illuminated (BSI) CMOS Imager manufactured on 18 $\mu\text{m}$  EPI layer of high resistivity silicon (1000 $\Omega\text{cm}$ ) by TowerJazz using their APD5 0.18 $\mu\text{m}$  process with the options of MIM capacitor and 6 layer metal. While warping of the wafer and not achieving the final flatness specification was a consideration (assessed to be within acceptable limits), going to 6 layer metal was thought critical to reduce IR (current\*resistance) drops (more, wider, thicker tracks) and thus the possibility of cross-talk between different parts of the design. Using their standard processes, e2v will thin the wafer to 12 $\mu\text{m}$  (to achieve PSF < 0.8 FWHM), and apply the necessary backside treatment of laser annealing, and 2-layer (Multi-2) AR coating. The expected QE is shown in Figure 1.

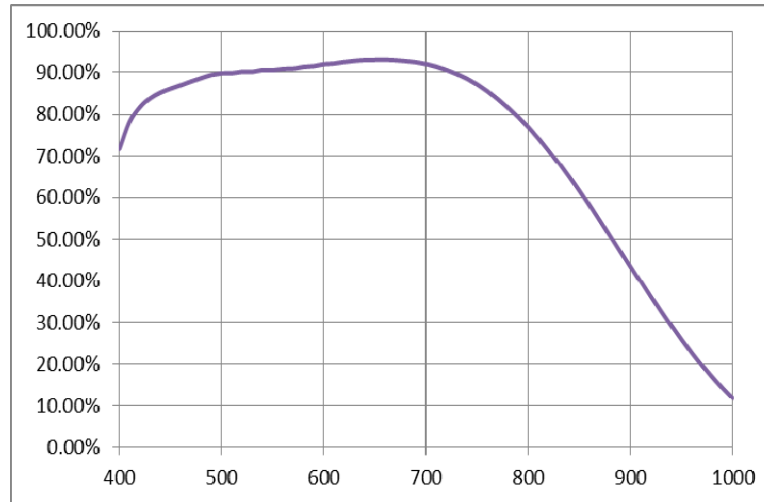

Figure 1. The expected QE response of NGSD versus wavelength at 20°C when thinned to 12  $\mu\text{m}$  and with e2v standard Multi-2 AR coating applied.

The design (Figure 2, and Figure 3) of the Imager consists of a 1760x1680 for LGSD and 880x840 for NGSD array of 24 $\mu\text{m}$  4T Pinned PhotoDiode (PPD) pixels. The central 1680x1680 for LGSD and 840x840 for NGSD pixels are light sensitive while the outer 40 for LGSD and 20 for NGSD columns either side will be optically masked and used as reference pixels if required. Pixels are addressed from the sides and twenty rows of pixels (one complete row of sub-apertures) are read out in parallel at the bottom in the case of the NGSD and at both top and bottom (40 pixel rows in total) for the LGSD. Each pixel (Figure 4) in these 20/40 rows (1760\*40 = 70,400 in case of LGSD) is read out through its own pre-amplifier, comparator and double data buffer (Register A and B). The pre-amplifier has four programmable gains of x1, x2, x4, and x8 that can be set on a granularity of a single sub-aperture (i.e. 20x20 pixel boundary). The comparator and Register A along with the common ramp generator and Gray Code Counter implement a single slope 9/10-bit ADC. For pipelining purposes, so that data can be serialized and transmitted off-chip while a fresh sample is taken, the ADC data is copied at the end of a conversion to a second (shadow) Register B so that it is ready to be serialized during the next sub-aperture read period. With 20/40 rows read in parallel at 700fps, the pixel processing time is ~ 34 $\mu\text{s}$  for both NGSD and LGSD. This was demonstrated in the Technology Validation phase to be adequate time to do the video processing and digitize the signal to achieve < 3e- rms read noise while still meeting the low latency requirements.

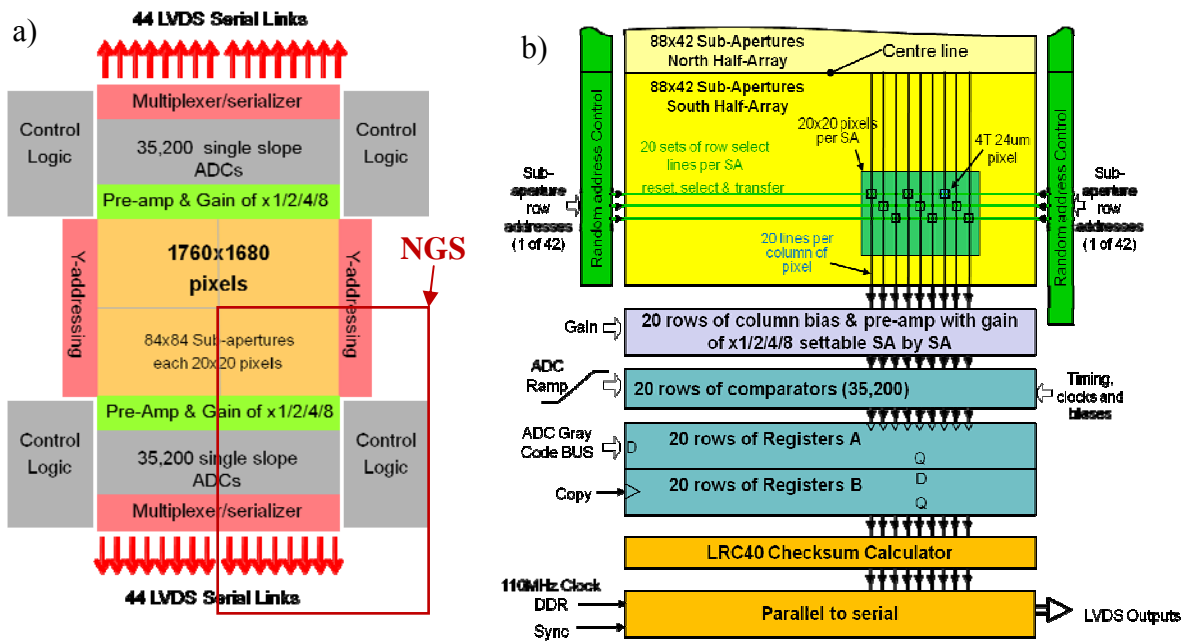

Figure 2. LGSD BSI CMOS imager: (a) Conceptual block diagram. The outline of the quarter sized NGSD scaled down demonstrator is shown in red. (b) Block diagram of the bottom half of the LGSD showing the read out in more detail.

The pre-amplifier gain, Y-address (sub-aperture row address), and various programmable options of the next sub-aperture to be read are up-loaded through a SPI (Serial Peripheral Interface) serial link during the current sub-aperture read. Rows of sub-apertures can thus be addressed sequentially (normal mode) or in any random order (e.g. for reading a sub-region) and gains of each sub-aperture can be independently updated on the fly.

For each 40 columns of pixels (width of two columns of sub-apertures), a shift register serializes the 20 rows of pixel data one row at a time using a 110MHz Double Data Rate (DDR) clock, and transmits the data off-chip through one of the 22 (NGSD) or 88 (LGSD) 220MHz LVDS serial links. A 40 bit LRC40 (Longitudinal Redundancy Check<sup>3</sup>) Checksum (detects single bit errors) is calculated each read cycle and can be optionally appended to the data stream.

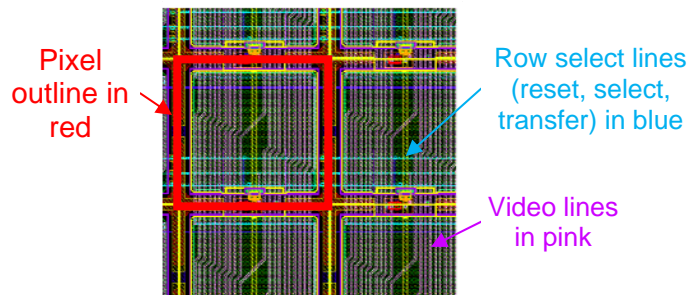

Figure 3. Layout of the pixel showing the three pixel select lines (reset, select and transfer) and the 20 long video lines that run the length of chip up and down from the center lines.

<sup>3</sup> [http://en.wikipedia.org/wiki/Longitudinal\\_redundancy\\_check](http://en.wikipedia.org/wiki/Longitudinal_redundancy_check)

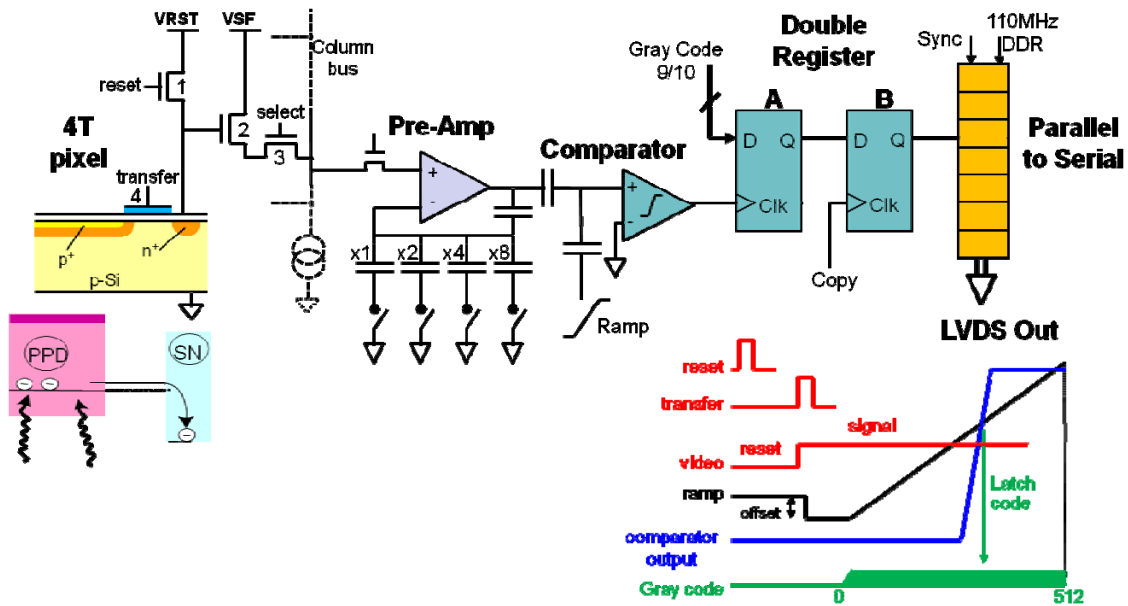

Figure 4. Details of the video processing chain showing pixel, programmable gain pre-amp, single slope ADC (consisting of comparator, Register A, Gray Code counter, and ramp generator), shadow Register B, and serializer (parallel to serial converter).

The analog to digital conversion has an effective resolution of 12/13 bits when the 9/10 bit ADC is combined with the 3 bits (1/2/4/8) of gain that can be update on the fly each read cycle. There is the restriction that gain is set on a fixed 20x20 pixel boundary, however, as explained in Figure 5 this is not an issue for the application of LGS wavefront sensing as the illumination pattern of elongated spots varies slowly across the detector and many sub-aperture sizes up to 20x20 can be accommodated.

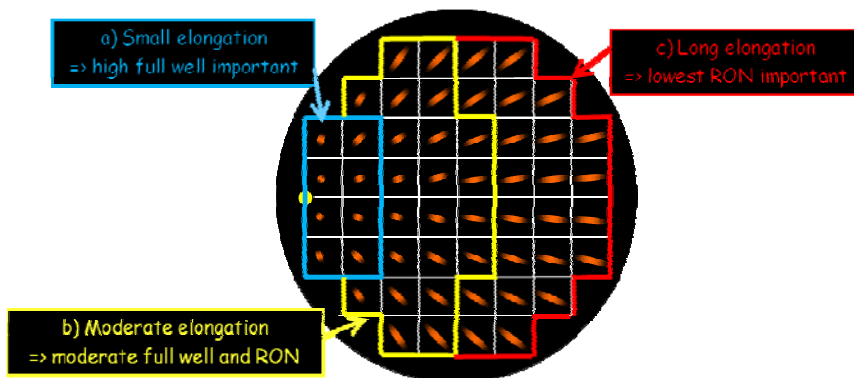

Figure 5. Shows why 9-bit resolution ADCs combined with regions that can be programmed with different gains is an acceptable compromise. Image shows a typical spot elongation pattern for side projected laser. Three different regions are identified: a) region of small elongation where detecting high signal is important, b) region of moderate elongation where moderate signal detector limit and read noise are acceptable, c) region of long elongation where lowest read noise (RON) is important.

The LGSD/NGSD has been designed with testability built in. Digital test patterns can be generated on-chip to check the serial data transmission and confirm correct operation of the Gray Code counter and associated control circuitry. Special switched bias structures at the top and bottom of the pixel array enable the CDS and ADC to be separately characterized for noise, linearity, monotonicity, and other functional tests. This testability as well as being very important for functional testing and characterizing of the detector during development will be available for use to test the operation of the camera electronics during its development and more important to confirm the operation of the camera in the field.

Further to ensure testability of the NGSD, a Mixed Boundary Scan (MBS) technique is used to program the possibility of injecting and observing signals at various points in the video chain of a column of pixels. This provides the capability to separately characterize individual components of the video chain, or, if performance issues occur, isolate the fault to a particular component.

The LGSD will be ~ 45mm x 50mm in size and thus will require stitching. The NGSD was sized to fit within a single reticle of 25.5mm x 32.5mm and thus not stitched. Even so the NGSD has been designed with stitching in mind (in order to be a true demonstrator). A tentative stitching plan<sup>[4]</sup> has been worked out, however, further work is required before the guidelines imposed by TowerJazz are fully met.

Half of the wafers of the first run of NGSD were manufactured using the more speculative, but much lower read noise (goal of 1e-), Ultra Low Threshold Transistors in the unit cell. Both types of devices will be tested and the best one selected for delivered devices. NGSD is mounted on a simple but custom 63 mm square, AlN, 370pin PGA package (Figure 6) designed to fit a 3M Textool socket style 1357. For temperature monitoring, two AD590MF sensors are glued on the front face at top and bottom close to the die. At the rear in the center of the package, an area as large as practical has been kept free of pins for clamping to a cold finger.

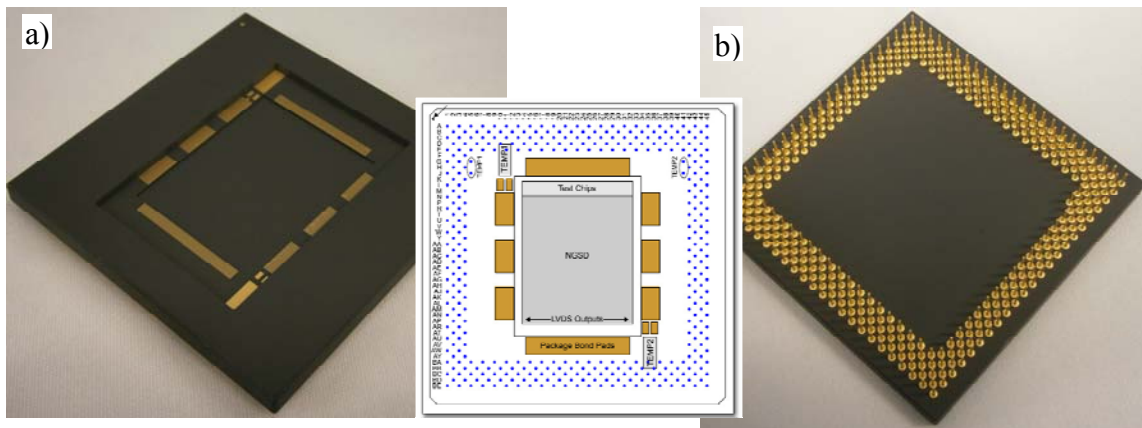

Figure 6. Photo of the custom 63 mm square Aluminum Nitride (AlN), 370pin PGA NGSD package, a) front and b) rear view.

### 3. FIRST TEST RESULTS

e2v has developed a Test Bench (controller Figure 7a) to fully characterize the NGSD. In parallel, ESO has built a simple bench prototype for initial assessment of the NGSD by interfacing the headboard that e2v developed to NGC (Figure 7b). This required minimal effort and again demonstrates the benefit of having an in-house controller.

A more substantial camera<sup>[5]</sup> that can be used at the telescope is also under development at ESO with first prototype scheduled to be available for device testing early 2015. As part of FP7, the same team<sup>4</sup> that successfully commercialized OCam for the CCD220 is developing a camera<sup>[6]</sup> for NGSD.

Wafers have come of production and one of the process Test Wafers (30  $\Omega$ cm silicon) has been diced up and packaged and used front-side illuminated (FSI) to commission the Test Benches, check device functionality and do first-light characterization. At the same time, a 1000  $\Omega$ cm epi wafer has gone through backside processing and is now ready for dicing up and packaging.

<sup>4</sup> Flight Light Imaging - <http://www.firstlight.fr/>

Unfortunately, due to wrongly wired protection diodes on the LVDS clock and synch inputs, no digital output data is possible, however, due to the inclusion of the MBS test structures it is possible to probe inside the device and fully characterize all except the serialiser and LVDS data interface. It is even possible to probe the outputs of the ADC latches at the input of the serializer and thus read one full column of pixel digital data. Results of testing of the FSI device (Table 1) is very encouraging with read noise of 2.3e- measured at effective frame rate of 700fps and pre-amplifier gain of 8 and good linearity at unity gain. This is impressive especially as at higher gains cross-talk from the comparators is seen on the video.



Figure 7. Photo of a) e2v Test Headboard/Controller, b) ESO adaption of the e2v Headboard interfaced to NGC.

Table 1. System gain and noise performance results of FSI device.

Preamp Gain	System Gain (e-/ADU)	Noise (ADU rms)	Noise (e- rms)	Full Signal (e-)
8	1.2	1.88	<b>2.3</b>	600e-
4	2.4	1.24	3.0	1200e-
2	4.7	0.83	3.9	2400e-
1	11	0.48	5.5	5000e-

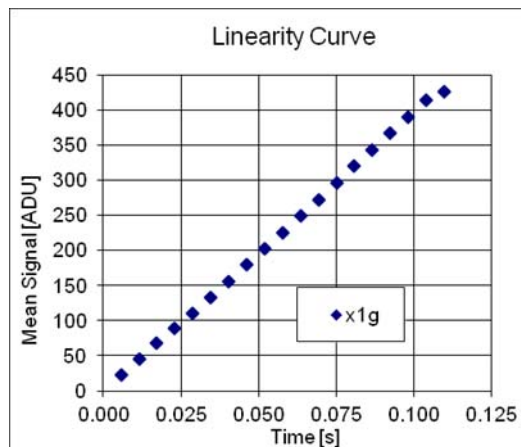

Figure 8. Plot of signal versus exposure time showing good linearity at unity gain.

## 4. FUTURE WORK

The next step is to test a BSI device to see if there are any differences to the FSI one. With the low impedance substrate removed, some of the cross-talk issues are expected to disappear. Following this, the devices with the Ultra Low Threshold Transistors in the unit cell will be tested to see if indeed that they work and whether they deliver the promised lower read noise.

Half of the wafers have been held back at TowerJazz. Several improvements by changing the metal layers on the wafers have been identified including fixing the wrongly wired protection diodes and reducing (eliminating) the cross-talk on the video. These changes will be implemented on two of the wafers held back at TowerJazz. With these changes there is great confidence that the performance of the device will be even better.

To ensure that devices are available for first light of the E-ELT, a possible production run of ~15 NGSD devices is envisaged. Upon successful demonstration of the NGSD, the full scale device will be developed (mainly an engineering exercise by this time) followed by a production run of 30-50 LGSD devices.

## 5. SUMMARY

Monolithic BSI CMOS Imager has been identified as the best technology to fulfill the challenging requirements of the Laser Guide Star detector for the E-ELT. The detailed design of the NGSD/LGSD was presented including the massive parallelism of reading out 70,400 pixels at a time. First results of the quarter-sized demonstration NGSD are very encouraging with read noise of 2.3e- rms (versus requirement of 3e- rms) and good linearity. Improvements have been identified that will be implemented by metal changes on held back wafers at TowerJazz. There is great confidence that this next batch of devices will easily exceed the requirements and the success of the LGS AO systems on the E-ELT will be assured.

ESO is well advanced in its camera development.

## 6. ACKNOWLEDGEMENT

ESO would like to thank their industrial partners and funding agencies (OPTICON<sup>[3]</sup> and E-ELT DS). Without their support and help this development work would have not been possible.

## REFERENCES

- [1] Downing M., et. al., "Detectors for AO wavefront sensing", Proc. SPIE 70151R-70151R-18, (2008).
- [2] Downing M., et. al., "AO Wavefront Sensing Detectors Development", Proc. SPIE 7742-4, (2010).
- [3] Davies J., <http://www.astro-opticon.org/>
- [4] Downing M., et. al., "Backside-Illuminated, high QE, 3e- RoN, fast 700fps, 1760x1680 pixels, CMOS Imager for AO with highly parallel readout", Proc. SPIE 84530C, Amsterdam, 2012.
- [5] Reyes J., et. al., "ESO adaptive optics controller for the E-ELT", Proc. SPIE 9154-51, (2014).
- [6] Feautrier P., et. al., "Visible and Infrared Wavefront Sensing Detectors Review", Scientific Detector Workshop, Florence 2013.