



Teledyne e2v sensors for adaptive optics: wavefront sensing on ELTs- high rate, large format, and low noise

Paul Jorden

Co-authors: D Bourke, R Cassidy, M Fryer, P Jerram, S Moore, J Pratloug

Teledyne e2v UK

AO4ELT5

29 June 2017

Tenerife

**e2v was acquired by
Teledyne in March 2017-
now part of a larger family!**

CONTENTS

Teledyne e2v sensors for Adaptive Optics

[Introduction](#)

[Sensor evolution: CCDs → CMOS](#)

[CCD wavefront sensor summary](#)

[The LVSM sensor for the ELT](#)

[Other CMOS sensors for astronomy & space](#)

[Systems](#)

[References & acknowledgements](#)

[Summary](#)

Introduction

Silicon detectors for wavefront sensing as components of AO systems

- We discuss here silicon sensors for Shack Hartmann wavefront sensing

CCDs are well established for this purpose on many telescopes

Larger telescopes use larger sensors- served by CMOS architectures

CMOS sensors offer high performance- comparable to CCDs in sensitivity and exceeding CCDs in data rate

- The Large Visible Sensor Module (LVSM)- a new large-format custom CMOS sensor- is presented

Other specialised CMOS sensors- for astronomy and space use- are also presented

All CCD and CMOS sensors discussed here are back-thinned for highest quantum efficiency

- Teledyne e2v has also developed significant capacity for supply of sub-systems- for space and astronomy use

Sensor evolution

From small CCDs to large CMOS sensors: 1000 frames/sec **Each detector requires a new company logo!**

CCDs
(1995- onwards)
→
CMOS
(2010- onwards)

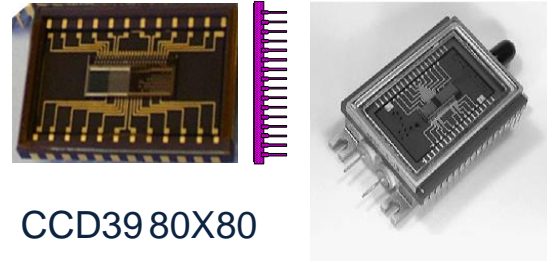

CCD39 80X80

CCD50
128X128

&

EM CCD60
128X128

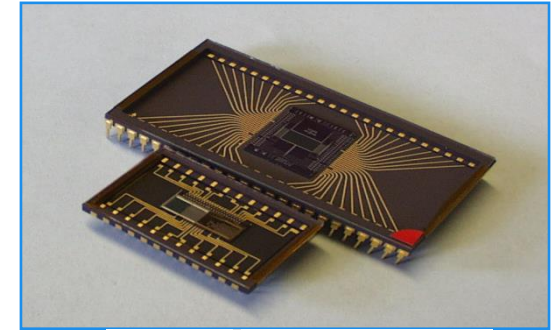

EEV SHORT-FORM DATA

Marconi

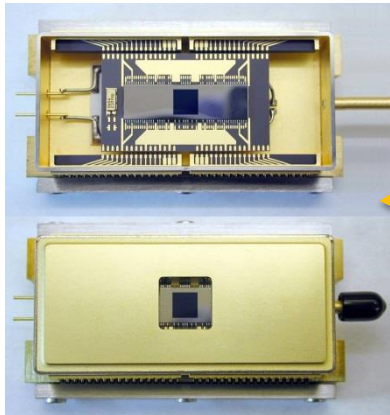

EM CCD220 240X240

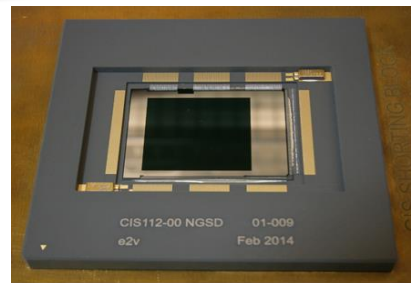

NGSD CIS112 880X840

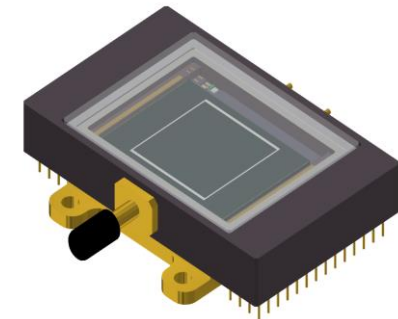

LVSM CIS124 800X800



Sensor evolution-2

Silicon detectors need to get larger as telescopes increase in size

Frame rates are in the 200 - 1000 frames per second range

CCDs are well established for this purpose on many telescopes

Small traditional CCDs can read out at adequate rates with low noise

Larger CCDs need higher pixel rates which would increase the read noise → requires EMCCD design

The largest telescopes have more sub-apertures and need larger sensors

Large areas at high frame rates become impractical for CCDs-

Data rate and number of outputs is too high and power consumption is too large

→ CMOS sensors offer large format, high frame rate, and low read noise

CCD and CMOS WFS sensors

Overview of key features

All sensors have 24 X 24 μm pixels and 90% back-thinned QE

Part Number	Image Format	Type	Read-noise e ⁻ rms	Frame rate Frames/sec	Outputs	Package	Status
CCD39-01	80 X 80	Standard CCD	5 @ 1 MHz/pixel	500	4	Ceramic or Peltier	Standard
CCD50	128 X 128	Standard CCD	5 @ 1 MHz/pixel	1000	16	Ceramic	Custom [superseded]
CCD60	128 X 128	EM CCD	< 1	~ 1000	1	Ceramic	Standard
CCD220	240 X 240	EM CCD	< 1	>1000	8	Peltier	Standard
CIS112 [NGSD]	800 X 840	CMOS	<4	700	20 LVDS	Ceramic PGA	Previous development
CIS124 [LVSM]	800 X 800	CMOS	<3	700	20 LVDS	Peltier	In development

A new CCD standard product

Before we get to CMOS sensors-

CCD351: a new standard product

- **L3Vision technology for sub-electron read-noise**
- **30 frames/sec readout**
- **Back-thinned high spectral response**

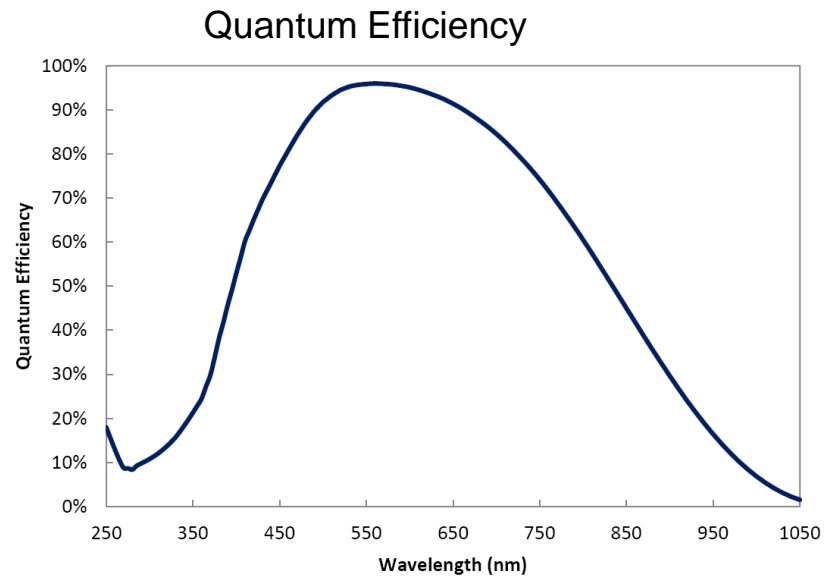
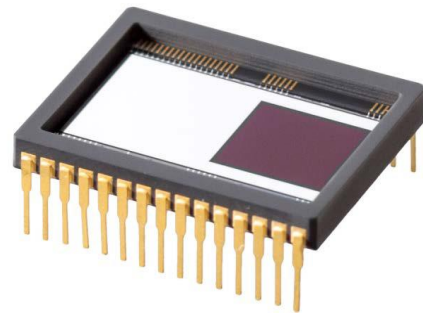

Typical Performance

Image section	1024 x 1024
Pixel size	10 μm \times 10 μm
Active image area	10.24 \times 10.24 mm
Package size Ceramic DIL	22.86 \times 28.00 mm
Amplifier responsivity	3.5 $\mu\text{V}/\text{e}^-$
Readout noise	$\ll 1 \text{ e}^-$ with EM gain 50 e^- at unity gain
Multiplication gain	100-1000 typical (variable)
Output data rate	37 MHz
Pixel charge storage	35 ke-/pixel
Dark signal (18°C)	100 $\text{e}^-/\text{pixel}/\text{s}$

Large Visible Wavefront Sensor-1

CIS124: A new CMOS sensor- in development for large telescopes

Key features

- **800 × 800** pixels: 80 × 80 sub-apertures of 10 × 10 pixels each.
- **Back illuminated** for highest QE and best intra-pixel uniformity.
- **24 μm** square pixels
 - + Each sub-aperture is 240 μm square.
- **700 fps** specified continuous readout (with 1000 fps goal).
 - + Lower frame rates/ longer integration times are also available.
- **< 3 e⁻** rms total readout noise.
- Nominal operating temperature **-10 °C** to minimise dark current.
- Rolling shutter for lowest noise.
 - + Parallel architecture allows low noise bandwidth with high frame rate.
- **On-chip ADC** giving digital outputs in LVDS.
- Low cross-talk and high uniformity between pixel readout paths.
- Hermetic package with internal **Peltier cooling**.

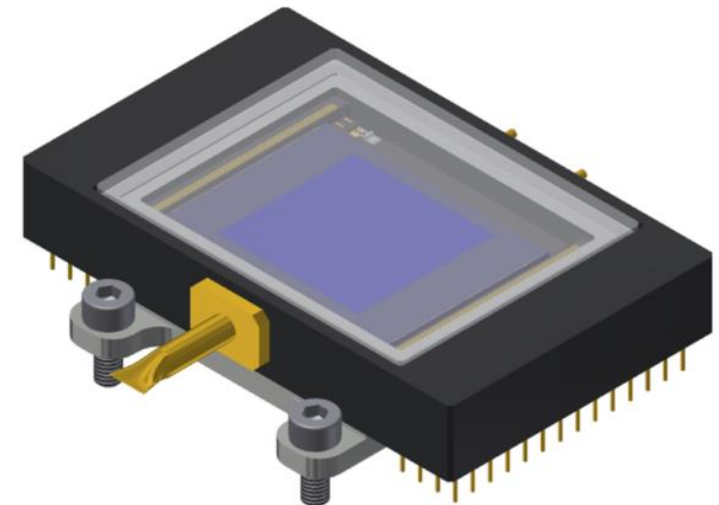

Large Visible Wavefront Sensor-2

Pixels and ADC

- Pixels are in one continuous array.
 - Allows use with other sub-aperture sizes.
- 20 dark reference columns on each side of pixel array for tracking dark level or for row noise subtraction.
- Readout is split into upper and lower sections.
- Column parallel ADC are used, with resolution programmable to 9 bit (fastest) or 10 bit (lowest noise).
- Programmable gain pre-amps used before ADC; each region of 40×40 pixels is independently set.
 - Four gain choices to effectively add three bits and increase the dynamic range.

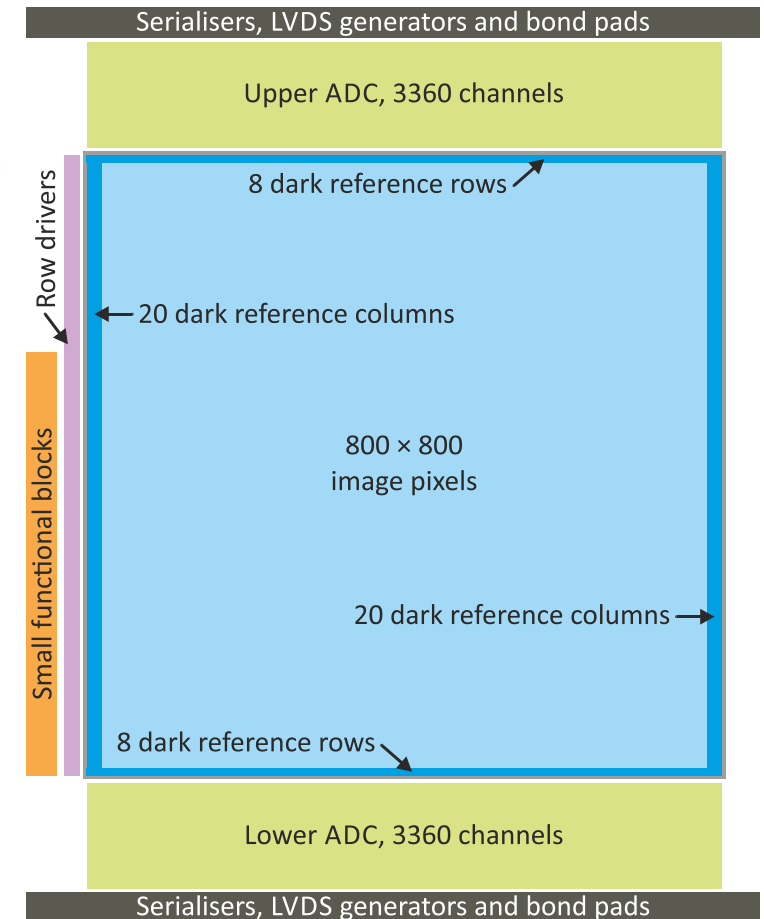

Large Visible Wavefront Sensor-3

ADC and data output

- Each ADC block has a single row, but the channel pitch is one quarter of the pixel pitch to allow two groups of four rows of pixels to be quantised in parallel.
 - Pixel output tracks (columns) are in sets of four.
 - Good non-synchronicity within each sub-aperture (< 2%).
 - Low latency within each sub-aperture (< 2% of exposure time).
- 3360 parallel channels in each half sensor.
 - ADC channels have great immunity to cross-talk.
- LVDS outputs for image data, dark reference pixels and data synchronisation.
- Multiple test and diagnostic features for both factory and field use.

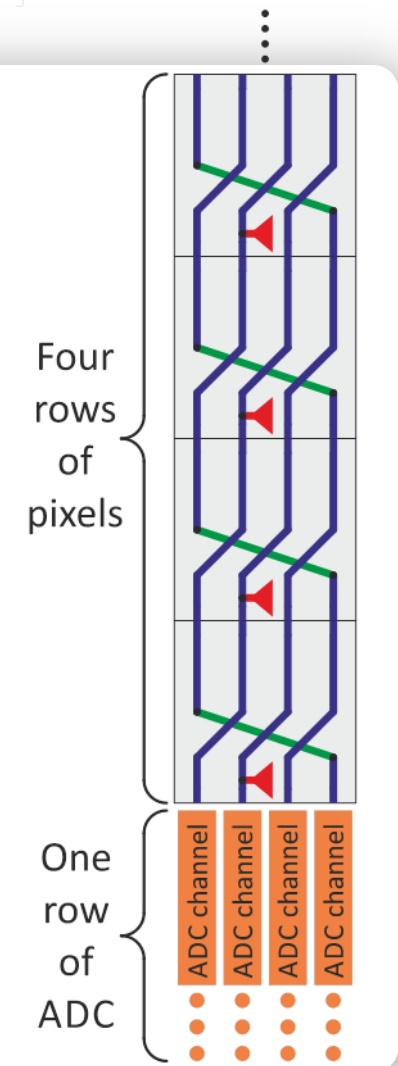

Large Visible Wavefront Sensor-4

Pixel read and data output

Pixel read

- ADC quantises all pixels of a four-row group simultaneously.
- Synchronicity and latency both good:
 - + Penultimate SA is 96th group, 97th group and first half of 98th group.
 - + Last SA is second half of 98th group, 99th group and then 100th group.

Data output

- Data read out in raster format.
- Pixel values transmitted in serial 9 (or 10) bit format.

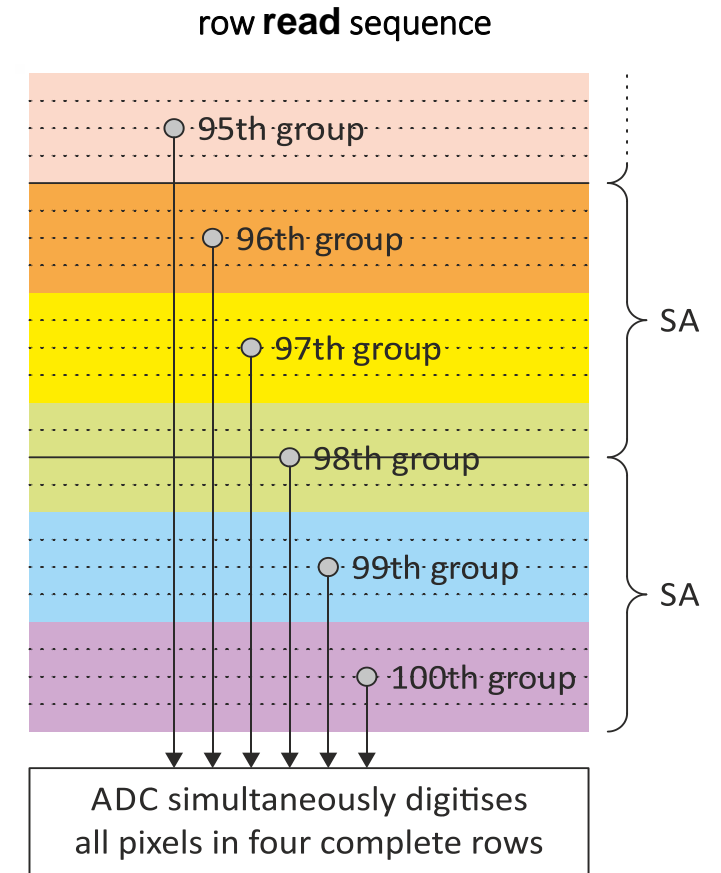

Figure illustrates last 24 rows and adjacent ADC block. Figure is for lower half of LVSM. Upper half is a mirror image.

Large Visible Wavefront Sensor-5

Timing features- for high rate, low latency, and efficient operation

- On-chip pixel read timing sequencer.
 - + All pixel timing pulses, including double sampling for CDS, are generated on-chip in the pixel sequencer.
- On-chip ADC sequencer.
 - + Input pins allow flexible start/stop ADC control. Other functions are internally generated automatically.
- On-chip data output sequencer.
 - + Readout is initiated by an input pin and then runs autonomously for each whole group of four rows, including generating the output data synchronisation signals.
- Optional on-chip PLL for fast clocks to ADC and data output.
- Serial-Parallel-Interface (SPI) to control the image sensor.

Large Visible Wavefront Sensor-6

Back-illumination for high spectral response and good uniformity

- With front illumination the front face features on CMOS image sensors reduce both photo-response uniformity and overall QE
- Back illumination allows a good AR coating to be used and then typically gives around 90 % QE at visible wavelengths. These sensors have a uniform detection surface and give superior intra-pixel uniformity compared to front illuminated sensors.

Typical BI QE curve:

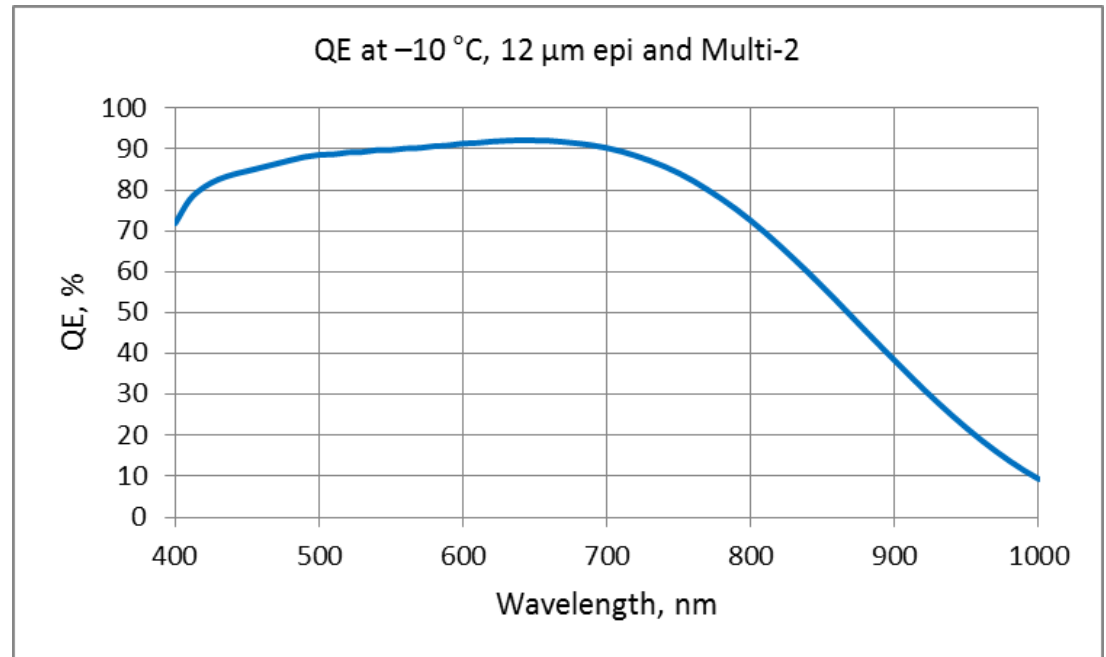

Large Visible Wavefront Sensor-7

Back-thinning metal shield

- Metal will be deposited on the back surface to make dark reference pixels and also to shield the read circuits from light.
- + The figure shows a CIS112 sensor with metal shield and the non-reflective AR coated surface of the image area:

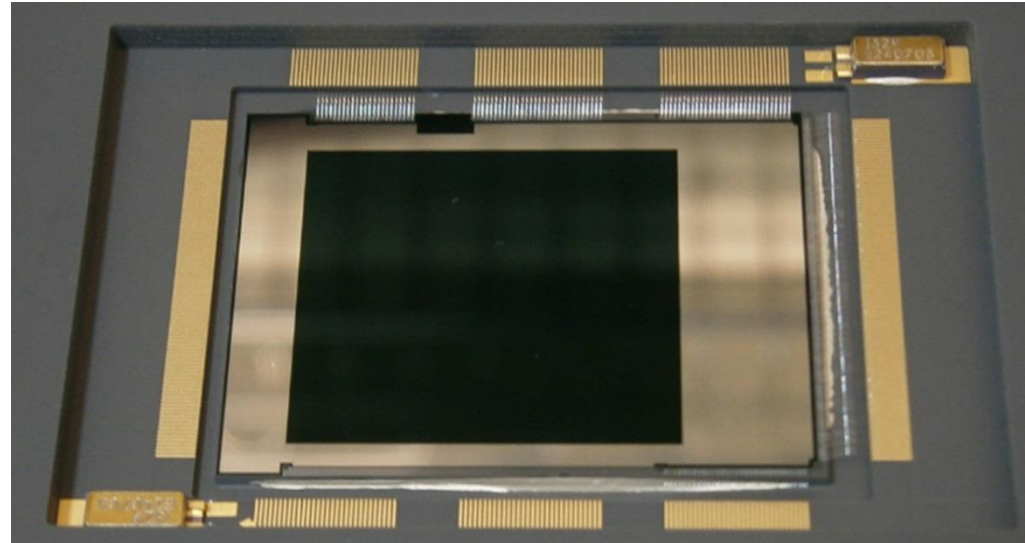

Large Visible Wavefront Sensor-8

Package

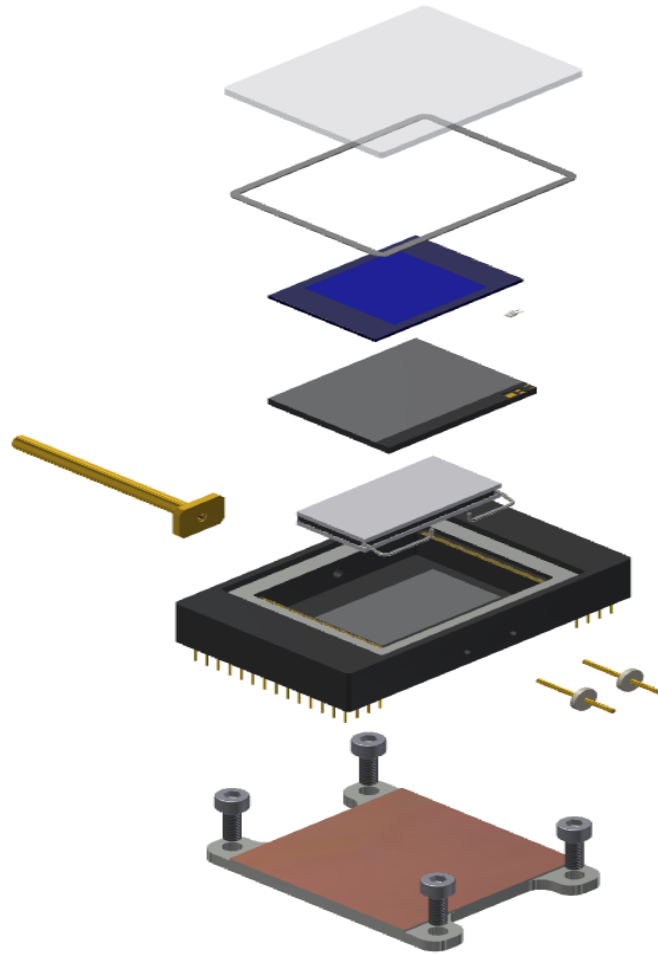

A ceramic body with:

- + Internal Peltier cooler with its power feedthroughs
- + Metal baseplate for mounting the module and for cooling the hot side of the Peltier
- + Hermetically sealed window
- + Low thermal conductivity inert gas filling
- + Pinched-off pump tube after filling with inert gas.
- + Pin grid arrays each side of baseplate
- + Temperature sensor

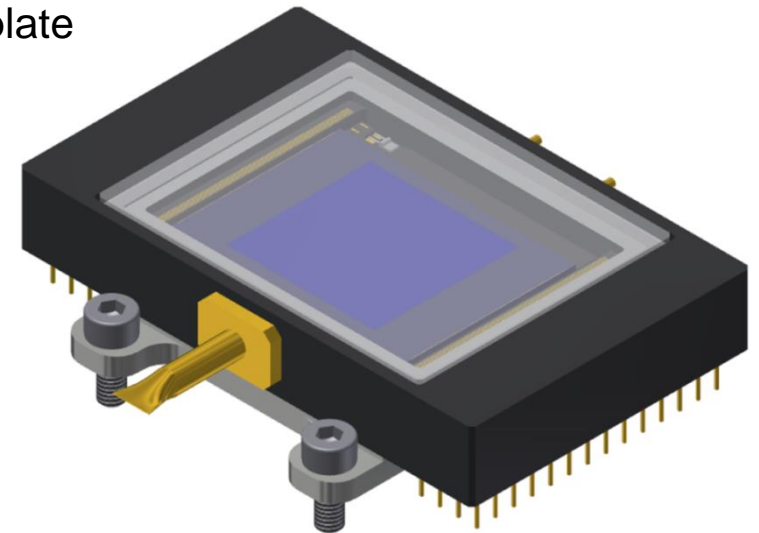

CMOS sensors for astronomy-1

CIS113

Developed for the TAOS-II project.

Development complete; 40-off devices delivered

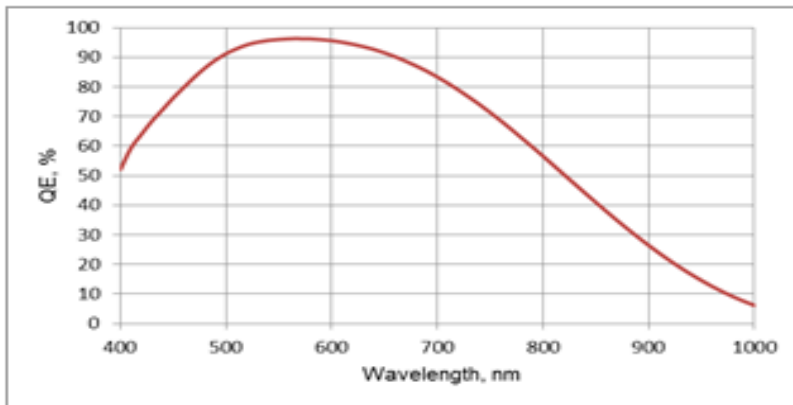

Number of pixels	1920 (H) × 4608 (V)
Pixel size	16.0 μm square
Image area	73.73m × 30.72 mm
Output ports (analogue)	8 (REF and SIG each)
Package size	82.39 mm × 31.7 mm
Package format	76 pin ceramic PGA attached to invar base
Focal plane height	14.0 mm
Flatness	< 30 μm (peak - valley)
Conversion gain	75 μV/e ⁻
Readout noise	3 e ⁻ at 2 MP/s per ch.
Maximum pixel rate	2 MP/s per channel
Maximum charge	22,000 e ⁻ per pixel
Dark signal	70 e ⁻ /pixel/s (at 21 °C)
Frame rate	2 fps (full frame mode) 20 fps (~1000 ROI's)

CMOS sensors for astronomy-2

Onyx EV76C664

- **Standard product with low noise**
- **Fully digital sensor with multiple modes**
- **Frontside illuminated with micro-lens**

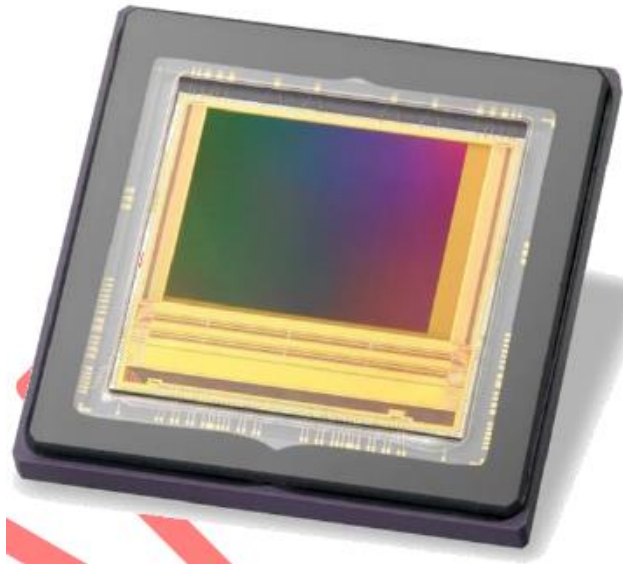

Key Features

Number of pixels	1280 X 1024 (1.3 Megapixel)
Pixel size	10.0 μm square
Shutter modes	Global and Rolling
Output	8, 10, 12, 14 bit LVDS
Package format	Ceramic 67-pin PGA
Readout noise	6 e^- (min, depending on mode)
Quantum Efficiency	Monochrome or sparse colour (with microlens)
Maximum charge	16,000 e^- per pixel

CMOS sensors for astronomy-3

CIS115

Key Features

- **Backthinned sensor with low read-noise**
- **Designed for space applications**
- **Planned for JANUS (Juice) ESA mission**
- **Being qualified for space use**
- **Samples available; FMs to follow**

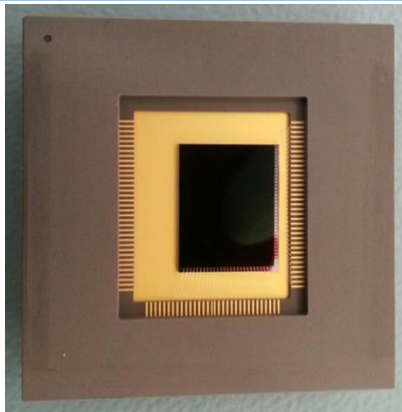

Number of pixels	1504(H) × 2000(V)
Pixel size	7.0 μm square
Number of output ports (reset and signal pins)	4 pairs of analogue outputs
Package size	48.26 mm square
Package format	140 pin ceramic PGA
Flatness	< 10 μm (peak to valley)
Conversion gain	35 μV/e ⁻
Readout noise	7 e ⁻ (Rolling shutter)
Maximum pixel data rate	8 MP/s per channel
Maximum charge per pixel	55,000 e ⁻
Frame rate	Up to 10 Hz
Minimum time to read one line at 6.2 MP/s	66.25 μs
Frame rate at full resolution	Up to 7.5 fps

Red sensitive CMOS

Demand for thick (>100 μm), fully depleted CMOS sensors for high QE

Near-IR imaging for astronomy, Earth observation, hyperspectral imaging, high speed imaging, spectroscopy, microscopy and surveillance.

Soft X-ray (<10 keV) imaging at synchrotron light sources and free electron lasers requires substrate thickness >200 μm

Low voltage CMOS sensors normally have small depletion depths

Key Features

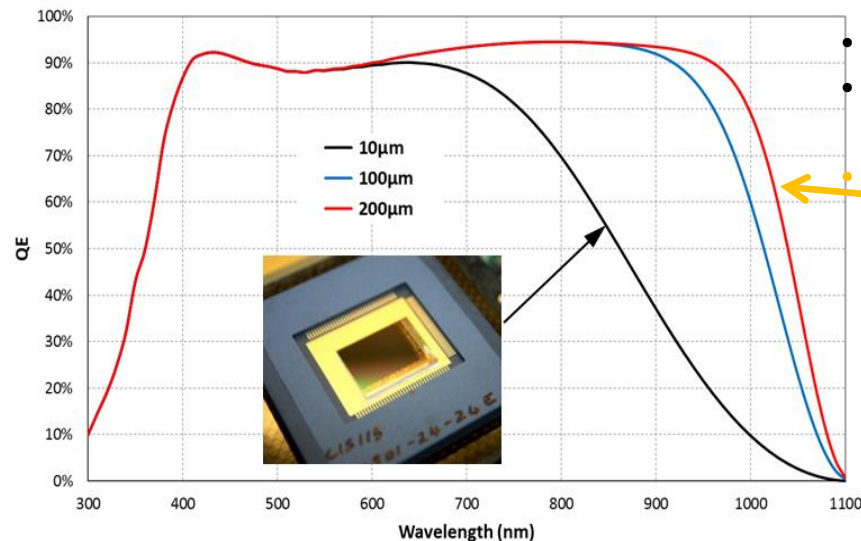

- Modified design concept to allow reverse-biased pixels
- Additional implants allows application of reverse bias to back surface with no leakage to front surface
- **Allows manufacture of thick silicon CMOS sensors with high RED QE**

In development; Teledyne e2v with CEI (Open University)
Acknowledgements to K Stefanov, CEI
Patent pending (owned by e2v Technologies)

Principle can be applied to any existing design **Watch this space!**

We also do systems for space and ground applications

J-PAS Cryocam: A 1.2 Gigapixel cryogenic camera

- 450 mm focal plane with 14 science CCDs; flat to 27 μm
- 224 synchronous readout channels with $< 5 e^-$ noise
- Integrated vacuum cryogenic system & thermal control



World Space Observatory UV Spectrograph sensors & electronics

- Three custom sensor channels for 115-310 nm range
- Sealed vacuum cryostat enclosures for 9 year life
- Flight electronics (associated with RAL Space)

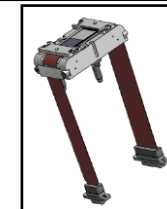
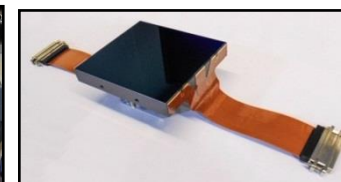
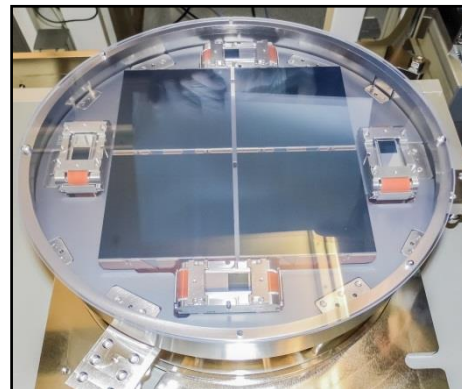
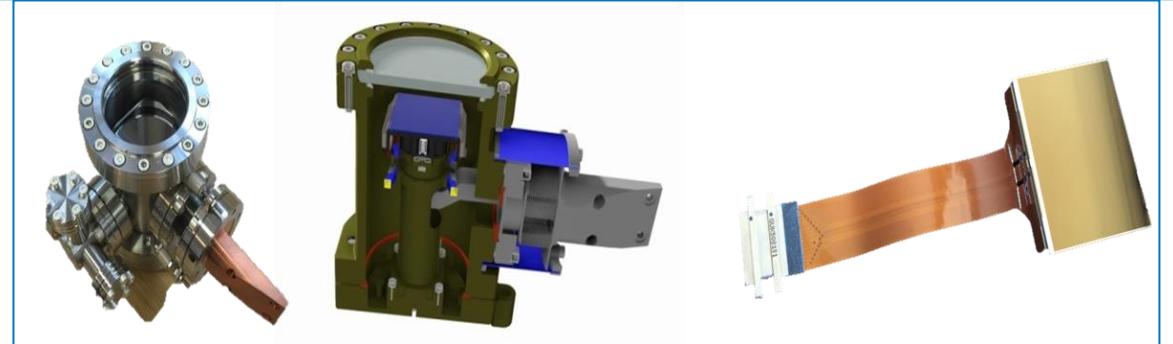

KMTNet precision focal planes

- 350 mm focal planes
- Three assembled plates
- Four science + 4 guide sensors
- Precision Silicon carbide plate

www.teledyne-e2v.com for datasheets and further information (CCD351, CIS113, CIS115, Onyx EV76C664, etc)

CIS113 Pratlong J, et al, *A 9 Megapixel large-area back-thinned CMOS sensor with high sensitivity and high frame rate for the TAOS II programme*. Proc SPIE 9915, 991514 (2016)

JPCam Robbins M, et al, *Performance of the e2v 1.2 GPix cryogenic camera for the J-PAS 2.5m survey telescope*, Proc SPIE 9908, 990811 (2016)

KMT B Atwood et al, *Design of the KMTNet large format CCD Camera*, Proc SPIE 8446 (2012)

Red sensitive CMOS K Stefanov et al, *Fully Depleted Pinned Photodiode CMOS Image Sensor with Reverse Substrate Bias*, IEEE EDL (2017)

With acknowledgements to co-authors: Denis Bourke, Ryan Cassidy, Martin Fryer, Paul Jerram, Stuart Moore, Jérôme Pratlong

And many thanks to multiple other contributors including ESO

Teledyne e2v has developed a range of specialised sensors for adaptive optics applications

- Designed with high frame rate, high spectral response, and low noise
- Large format for ELT use; smaller formats also available; CCD and CMOS technologies
- Low latency and good uniformity for different sub-aperture sizes
- High sensitivity for natural and laser guide star use
- Custom packages and Peltier cooling supplied

We are currently developing the next generation of large-format high frame-rate sensor for ELT use

- This “LVSM” CMOS sensor has a 2-year development timeframe.

Teledyne e2v also designs and manufactures other custom CCD and CMOS sensors for astronomical use

Teledyne e2v designs and supplies sub-systems and systems for ground-based and space use

Thank you for your attention